

# AF2/FT14

## Operator's Manual



CMW®

Issue 1.0



054- 138

---

# Overview



## Chapter Contents

<b>Serial Number Location</b> . . . . .	<b>2</b>
<b>Intended Use</b> . . . . .	<b>3</b>
<b>Unit Components</b> . . . . .	<b>3</b>
<b>About This Manual</b> . . . . .	<b>4</b>
• Bulleted Lists . . . . .	.4
• Numbered Lists . . . . .	.4
• "Continued" Indicators . . . . .	.4

## Serial Number Location

Record serial numbers and date of purchase in spaces provided. Serial numbers are located as shown.

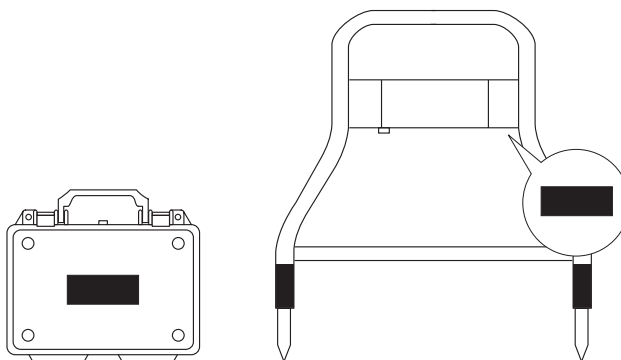

e05om017c.eps

Date of manufacture	
Date of purchase	
AF2 serial number	
FT14 serial number	



## Intended Use

The AF2/FT14 is a fault locating system designed to locate faults in de-energized cables that are disconnected on both ends. The unit is designed for operation in temperatures typically experienced in earth moving and construction work environments. Use in any other way is considered contrary to the intended use.

The AF2/FT14 system should be operated only by persons familiar with its particular characteristics and acquainted with the relevant safety procedures. The system should be serviced only by authorized Subsite Electronics repair centers.

## Unit Components

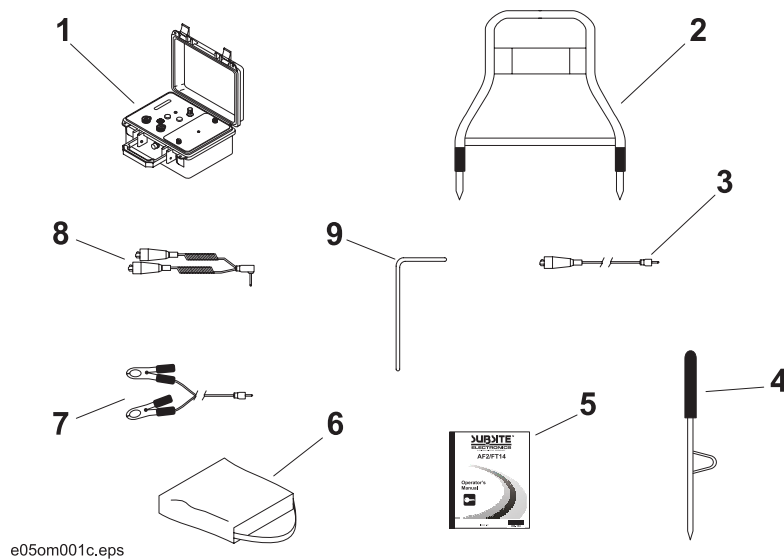

- |                          |                              |
|--------------------------|------------------------------|
| 1. transmitter           | 6. accessory bag             |
| 2. detector              | 7. auxiliary battery cable   |
| 3. remote probe cable    | 8. high-voltage output cable |
| 4. remote detector probe | 9. ground probe              |
| 5. operator's manual     |                              |

## About This Manual

This manual contains information for the proper use of this unit. See **Operation Overview** for basic operating procedures. Cross references such as "See page 50" will direct you to detailed procedures.

### Bulleted Lists

Bulleted lists provide helpful or important information or contain procedures that do not have to be performed in a specific order.

### Numbered Lists

Numbered lists contain illustration callouts or list steps that must be performed in order.

### "Continued" Indicators



indicates that a procedure is continued on the next page.

---

# Foreword



This manual is an important part of your equipment. It provides safety information and operation instructions to help you use and maintain your Subsite Electronics equipment.

Read this manual before using your equipment. Keep it with the equipment at all times for future reference. If you sell your equipment, be sure to give this manual to the new owner.

If you need a replacement copy, contact your Subsite Electronics dealer. If you need assistance in locating a dealer, visit our website at **[www.ditchwitch.com](http://www.ditchwitch.com)** or write to the following address:

The Charles Machine Works, Inc.  
Attn: Subsite Electronics  
PO Box 66  
Perry, OK 73077-0066  
USA

The descriptions and specifications in this manual are subject to change without notice. The Charles Machine Works, Inc. reserves the right to improve equipment. Some product improvements may have taken place after this manual was published. For the latest information on Subsite Electronics equipment, see your Subsite Electronics dealer.

Thank you for buying and using Subsite Electronics equipment.

**AF2/FT14  
Operator's Manual**

**Issue number 1.0/OM-2/05**

**Part number 054-138**











**Copyright 2005**

**by The Charles Machine Works, Inc.**

Subsite is a registered trademark of The Charles Machine Works, Inc.

# Contents



	<b>Overview</b> machine serial number, information about the type of work this machine is designed to perform, basic machine components, and how to use this manual	<b>1</b>
	<b>Foreword</b> part number, revision level, and publication date of this manual, and factory contact information	<b>5</b>
	<b>Safety</b> machine safety alerts and emergency procedures	<b>9</b>
	<b>Controls</b> machine controls and indicators and how to use them	<b>13</b>
	<b>Prepare</b> procedures for preparing the equipment for work	<b>19</b>
	<b>Operating the System</b> procedures for locating faults	<b>21</b>
	<b>Locating Concepts</b> procedures for advanced fault locating	<b>35</b>
	<b>Complete the Job</b> procedures for storing equipment	<b>39</b>
	<b>Service</b> service intervals and instructions for this machine	<b>41</b>
	<b>Specifications</b> machine specifications including weights, measurements, and power requirements	<b>43</b>
	<b>Support</b> the warranty policy for this machine, and procedures for obtaining warranty consideration and training	<b>45</b>



---

# Safety

## Chapter Contents

Guidelines . . . . .	10
Safety Alert Classifications . . . . .	11
Safety Alerts . . . . .	12



## **Guidelines**

Follow these guidelines before operating any jobsite equipment:

- Complete proper training and read operator's manual before using equipment.
- Classify jobsite based on its hazards and use correct tools and machinery, safety equipment, and work methods for jobsite.
- Mark jobsite clearly and keep spectators away.
- Wear personal protective equipment.
- Review jobsite hazards, safety and emergency procedures, and individual responsibilities with all personnel before work begins.
- Replace missing or damaged safety signs.
- Use equipment carefully. Stop operation and investigate anything that does not look or feel right.
- Contact your Subsite Electronics dealer if you have any question about operation, maintenance, or equipment use.

## Safety Alert Classifications

These classifications and the icons defined on the following pages work together to alert you to situations which could be harmful to you, jobsite bystanders or your equipment. When you see these words and icons in the book or on the unit, carefully read and follow all instructions. **YOUR SAFETY IS AT STAKE.**



Watch for the three safety alert levels: **DANGER**, **WARNING** and **CAUTION**. Learn what each level means.

 **DANGER** indicates an imminently hazardous situation which, if not avoided, will result in death or serious injury.

 **WARNING** indicates a potentially hazardous situation which, if not avoided, could result in death or serious injury.

 **CAUTION** indicates a potentially hazardous situation which, if not avoided, may result in minor or moderate injury.

Watch for two other words: **NOTICE** and **IMPORTANT**.

**NOTICE** can keep you from doing something that might damage the unit or someone's property. It can also alert you against unsafe practices.

**IMPORTANT** can help you do a better job or make your job easier in some way.

## Safety Alerts

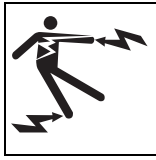

**⚠ DANGER** Electric shock. Contacting electric lines will cause death or serious injury. Know location of lines and stay away.

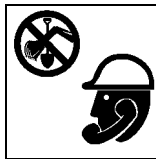

**⚠ WARNING** Jobsite hazards could cause death or serious injury. Use correct equipment and work methods. Use and maintain proper safety equipment.



**⚠ WARNING** Explosion possible. Serious injury or equipment damage could occur. Follow directions carefully.

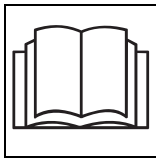

**⚠ WARNING** Incorrect procedures could result in death, injury, or property damage. Learn to use equipment correctly.



**⚠ WARNING** Moving traffic - hazardous situation. Death or serious injury could result. Avoid moving vehicles, wear high visibility clothing, post appropriate warning signs.

---

# Controls

## Chapter Contents

AF2 Fault Finder .....	14
FT14 Fault Transmitter .....	16



# AF2 Fault Finder

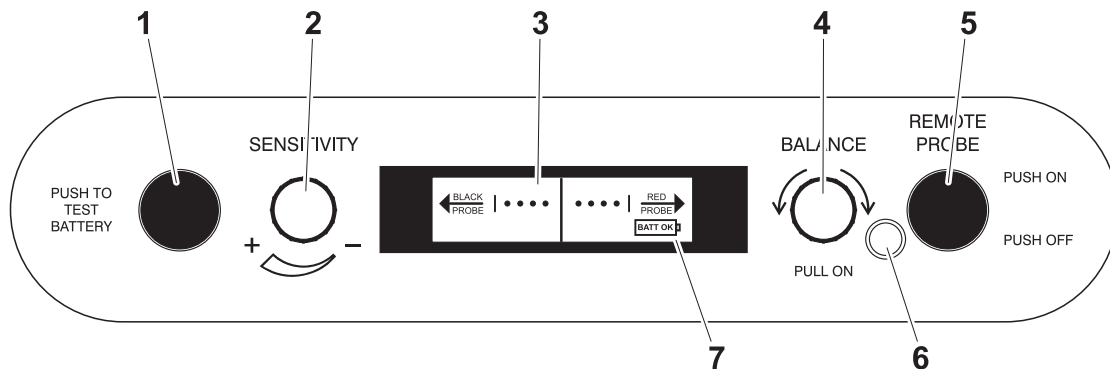

e05om002c.eps

- |                          |                                |
|--------------------------|--------------------------------|
| 1. Battery test switch   | 5. Remote probe switch         |
| 2. Sensitivity knob      | 6. Remote probe mode indicator |
| 3. Analog meter          | 7. Battery OK indicator        |
| 4. Balance/power control |                                |

Item	Description	Notes
1. <b>Battery test switch</b>	To test battery, turn on unit and press and hold switch.  If meter deflects fully to the right, battery is good.  If meter does not move or deflects fully to the left, battery needs to be replaced.	
2. <b>Sensitivity knob</b>	To increase sensitivity, rotate clockwise.  To decrease sensitivity, rotate counter-clockwise.	<b>IMPORTANT:</b> Increasing sensitivity allows detection of weaker signals.
3. <b>Analog meter</b>	Meter deflection indicates transmitter signal pulses and leads operator to the fault.  In battery test mode, deflection indicates battery status.	<b>IMPORTANT:</b> Detector must be oriented with red probe toward transmitter for deflection to lead to the fault.

Item	Description	Notes
4. <b>Balance/Power switch</b>	To turn on, pull switch. To turn off, push switch. To move needle toward red probe, turn clockwise. To move needle toward black probe, turn counter-clockwise.	<b>IMPORTANT:</b> Center needle on analog scale before turning transmitter on.
5. <b>Remote probe switch</b>	To enable, press. To disable, press again.	
6. <b>Remote probe mode indicator</b>	Lights when remote probe mode is on.	
7. <b>Battery OK indicator</b>	Meter deflection to this point during battery check indicates battery power is OK.	



# FT14 Fault Transmitter

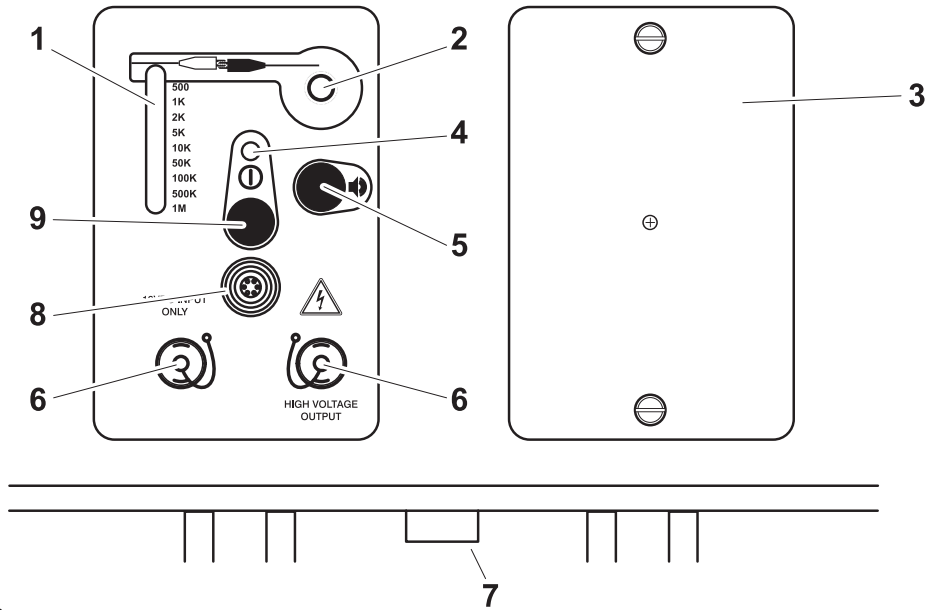

e050m003c.eps

- |                             |                     |
|-----------------------------|---------------------|
| 1. Line impedance indicator | 6. Cable connectors |
| 2. Calibration knob         | 7. Signal indicator |
| 3. Battery compartment      | 8. Speaker          |
| 4. Power indicator          | 9. Power switch     |
| 5. Speaker switch           |                     |

Item	Description	Notes
1. <b>Line impedance indicator</b>	Lights indicate the amount of impedance on the line. More lights indicate lower impedance.	<b>IMPORTANT:</b> Lower impedance means the signal has a better path to ground.
2. <b>Calibration knob</b>	To calibrate transmitter at jobsite, turn as directed on page 22.	
3. <b>Battery compartment</b>	Houses unit batteries.	See "Replace Transmitter Batteries and Fuse" on page 42.

Item	Description	Notes
4. <b>Power indicator</b>	Lights when unit is on and high-voltage output cable is connected properly.	
5. <b>Speaker switch</b>	To turn off, press.  To turn on, press again.	
6. <b>Cable connectors</b>	To connect high-voltage cable properly, insert into connector on right marked "High Voltage Output."  To connect auxiliary battery cable properly, insert into connector on left marked "12 Volt Input Only."	
7. <b>Signal indicator</b>	Lights when signal is being transmitted.	<b>IMPORTANT:</b> Speaker and indicator are controlled by speaker switch. If speaker is off, indicator is off.
8. <b>Speaker</b>	Emits audible tones that correspond with transmitter signal pulses when speaker switch is on.	
9. <b>Power switch</b>	To turn on, press.  To turn off, press again.	





---

# Prepare

## Chapter Contents

**Check Battery Status . . . . . 20**

- Detector . . . . .20
- Transmitter . . . . .20



## Check Battery Status

### Detector

Check battery status before each use, after each battery change, and as desired during operation.

#### To check

1. Turn detector on.
2. Press battery check button.
3. Watch meter deflection.
  - If meter deflects fully to "Batt OK" area, battery is good.
  - If meter does not deflect to "Batt OK" area, replace battery.

### Transmitter

**⚠ WARNING**

Incorrect procedures could result in death, injury, or property damage.  
Learn to use equipment correctly.

**NOTICE:** Do not touch leads to avoid electric shock during transmitter pulses.

Check battery status before each use and after each battery change.

#### To check

1. Connect high-voltage output cable to transmitter.
2. Connect red lead to black lead.
3. Turn transmitter on.
4. Turn calibration knob fully clockwise.
5. Watch impedance indicator.
  - If all lights do not come on, replace batteries.
  - If all lights come on, batteries are OK.
6. Turn transmitter off and disconnect leads.

---

# Operate the System

## Chapter Contents

<b>Calibrate Transmitter</b> .....	<b>22</b>
<b>Connect Transmitter External Power Source</b> ...	<b>23</b>
<b>Connect Transmitter</b> .....	<b>24</b>
<b>Calibrate Detector</b> .....	<b>25</b>
<b>Locate Fault</b> .....	<b>26</b>
• Standard Method .....	26
• Using Remote Probe .....	29
• Special Situations .....	31



## Calibrate Transmitter

Calibrate transmitter before each use and after each battery change.

### To calibrate

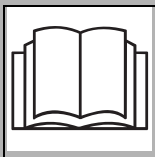

**⚠ WARNING** Incorrect procedures could result in death, injury, or property damage.  
Learn to use equipment correctly.

**NOTICE:** Do not touch leads to avoid electric shock during transmitter pulses.

1. Connect high-voltage output cable to transmitter.
2. Connect red lead to black lead.
3. Turn transmitter on.
4. Turn calibration knob fully counterclockwise and then turn clockwise until all lights are on during the transmitted pulse.
5. Turn transmitter off and disconnect leads.

## Connect Transmitter External Power Source

Transmitter can be powered by an external 12V DC power source. External power can be useful when batteries run low and when a job requires transmitter to operate longer than internal batteries will allow. Any 12V DC source capable of delivering 4A is a suitable provider of external power.

### To use external power

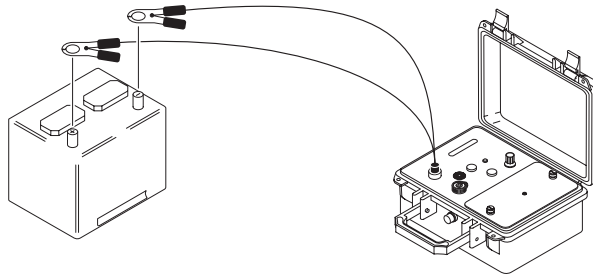

e05om009c.eps



**WARNING**

Explosion possible. Serious injury or equipment damage could occur. Follow directions carefully.

**NOTICE:** Always remove batteries before external power source is used.

1. Turn off transmitter.
2. Remove one or more batteries. See "Replace Transmitter Batteries and Fuse" on page 42. Install battery cover to prevent moisture and contaminants from entering transmitter housing.
3. Connect auxiliary battery cable to the cable receptacle on the transmitter.
4. Connect auxiliary battery cable's black clamp to the negative (-) terminal on the external power source and the red clamp to the positive (+) terminal.

**NOTICE:** Always observe proper battery polarity or damage to the transmitter may result.



## Connect Transmitter



**⚠ DANGER**

Electric shock. Contacting electric lines will cause death or serious injury. Know location of lines and stay away.

### NOTICE:

- Do not connect transmitter to live cable. Have qualified utility personnel disconnect cable at both ends.
- Do not touch bare metal parts of equipment. Wear electrically-insulating rubber gloves.
- Detector is not insulated against direct contact with high-voltage power lines.

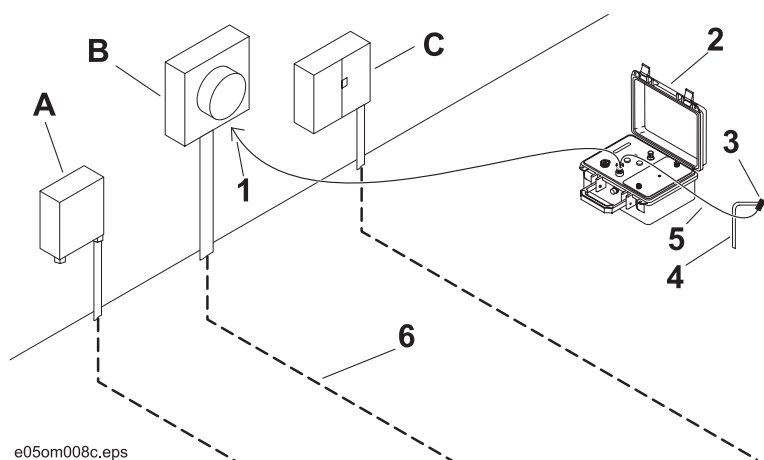

e05om008c.eps

A. CATV box B. meter box C. telephone box

1. Check battery status and calibrate the display.
2. Place transmitter (2) on the ground about 5' (1.5 m) from the faulted cable (6). Start at the house end on a residential cable.
3. Connect high voltage output cable (5) to transmitter.
4. Connect black clip (3) from the high voltage cable to the ground probe (4).

**NOTICE:** Always turn off transmitter when connecting or moving ground probe.



5. Stretch black coiled cable as far as possible (approximately 5'/1.5 m) and push ground probe into the ground perpendicular to the faulted cable.
6. Connect red clip (1) from high voltage output cable to the de-energized faulted cable.

**IMPORTANT:** Other end of cable must be disconnected from all sources, including ground, and not attached to anything.

7. Turn on transmitter. The lights indicate approximate impedance of the faulted cable. The lower the impedance, the better the signal goes to ground through the fault or through a ground on the cable.

## Calibrate Detector

Calibrate detector to local soil conditions before each use and after each battery change. Adjustments may be necessary during use as conditions change.

### To calibrate



**⚠ DANGER**

Electric shock. Contacting electric lines will cause death or serious injury. Know location of lines and stay away.

**NOTICE:**

- Do not connect transmitter to live cable. Have qualified utility personnel disconnect cable at both ends.
  - Do not touch bare metal parts of equipment. Wear electrically-insulating rubber gloves.
  - Detector is not insulated against direct contact with high-voltage power lines.
1. Position detector with red probe toward transmitter and black probe toward route of faulted cable. With transmitter off, stand close to transmitter and push probes into the ground.
  2. Turn on detector and test battery power. See "Check Battery Status" on page 20.
  3. Rotate sensitivity control until index mark on knob is close to 12 o'clock position.
  4. Rotate balance until meter needle is in the center of the scale.
  5. Turn on transmitter and verify that meter needle deflects from center.
  6. Adjust sensitivity knob until needle softly hits meter edge during each transmitter pulse.

## Locate Fault

**⚠ DANGER**

Electric shock. Contacting electric lines will cause death or serious injury. Know location of lines and stay away.

**NOTICE:** Do not connect transmitter to live cable. Have qualified utility personnel disconnect cable at both ends.

### Standard Method

This system locates faults that are grounded at the point of the fault. This method is most effective on direct-buried, grounded faults because the transmitter pulse is allowed to travel to ground. This is not always true with direct-buried, non-shielded conductors.

### Known Cable Route

1. Turn on transmitter and check battery status.
2. Connect transmitter to de-energized and isolated faulted cable and turn on transmitter.
3. Turn on detector and check battery status.
4. Position red probe toward transmitter and ensure detector is not in remote probe mode.
5. Insert detector in the ground along cable route.

**IMPORTANT:** Take hands off detector once it is in the ground for a clearer reading.

6. When transmitter sends out a pulse, meter will deflect toward the direction of the fault on the cable.
7. Move 10' (3 m) down the cable route and insert detector again, keeping red probe toward transmitter.



8. As you move away from the meter riser, detector may stop indicating transmitter pulses. As you near the fault, detector will resume indicating transmitter pulses. This is normal. Transmitter pulses are strongest at the point of the fault and at the transmitter ground.

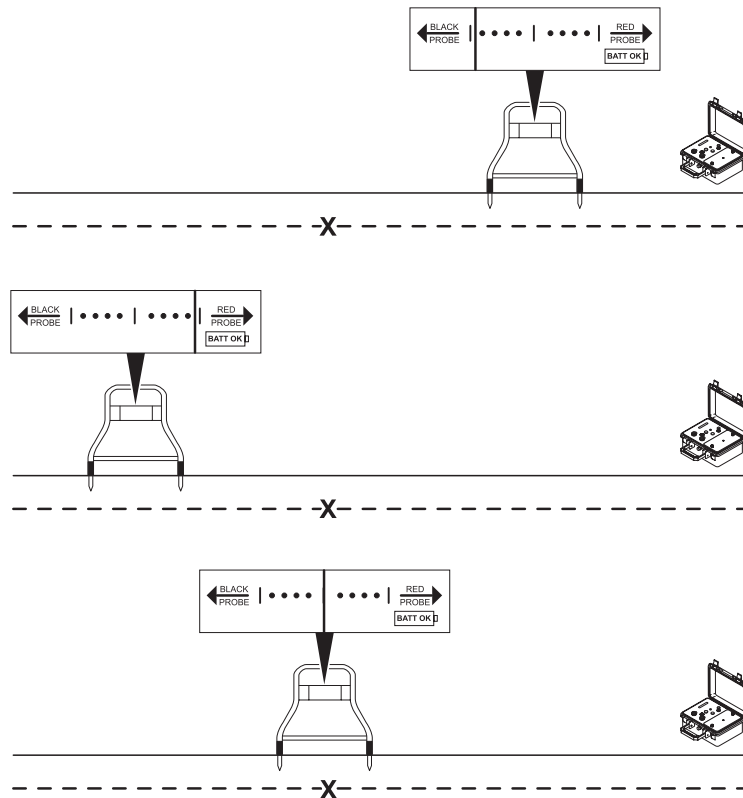

e05om010c.eps



9. After meter deflects in the opposite direction, keep detector in same orientation and insert detector a few feet (meters) back down the line. Repeat until meter reverses direction again as transmitter pulses.
10. When deflection changes direction after only a few inches (millimeters) of movement, draw an X halfway between detector probes.
11. Confirm fault location by inserting red probe at the center of the X (1) and note deflection.
12. Pivot detector around this point and take readings at 90° intervals (2, 3, 4).
- If meter deflection at other points matches reading at original position (5), red probe is over fault.
  - If meter deflection does not match original position each time, return to meter riser and locate fault again.

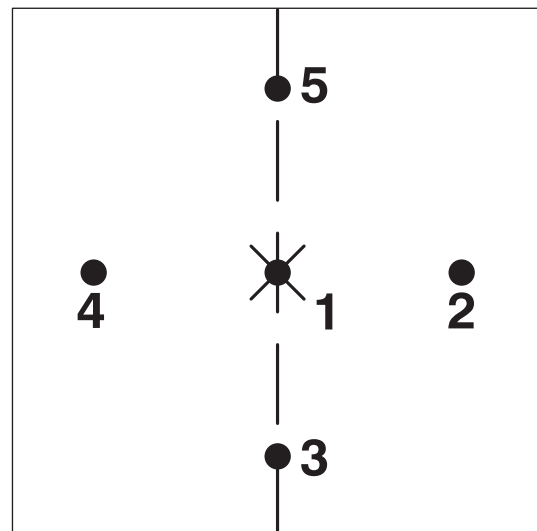

e05om016c.eps

## Troubleshooting

If meter does not deflect toward the fault in the line, transmitter ground is giving a false indication or the fault is in the meter riser.

- Check transmitter ground probe placement and connect high voltage output cable black clip to secondary service ground at meter socket.
- If meter still does not deflect toward fault in the line, see "Locating Fault at Meter Riser" on page 31.

## Unknown Cable Route

In many cases, detector can pick up a fault as far as 15' (4.5 m) away from the cable.

1. Based on signs of possible cable location on "Finding General Location of a Faulted Cable" on page 36, select some presumed cable routes.
2. Locate fault along most likely cable route as indicated in steps 1-9 in "Standard Method" on page 26. If meter deflection does not reverse after walking the entire length of the route, return to the meter riser (2) and try another route.
3. When deflection changes direction after only a few inches (centimeters) of movement, draw a line halfway between and perpendicular to detector probes. This is one coordinate of the fault (1).
4. Rotate detector at a right angle to the midpoint marked between the detector probes and move along this line in the direction indicated by the meter deflection.
5. When deflection reverses, probe back and forth until deflection changes direction after only a few inches (centimeters) of movement. Draw a line halfway between and perpendicular to detector probes. This is the second coordinate of the fault (2).
6. Rotate detector at a right angle to the midpoint marked between the detector probes and move along this line in the direction indicated by the meter deflection.

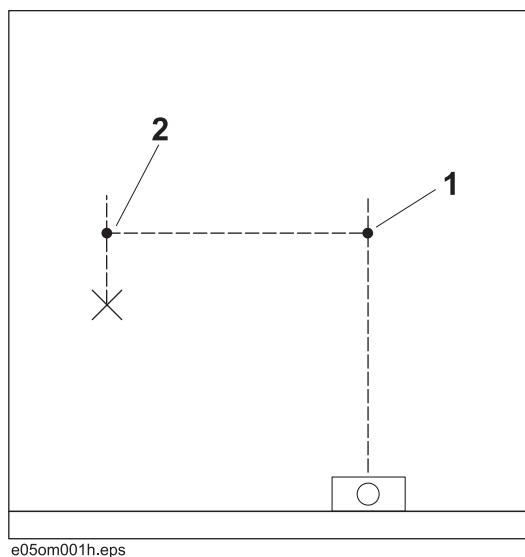

7. When deflection changes direction after only a few inches (centimeters) of movement, draw an X halfway between detector probes.
8. Confirm fault location by inserting red probe at the center of the X (1) and note deflection.
9. Pivot detector around this point and take readings at 90° intervals (2, 3, 4).
  - If meter deflection at other points matches reading at original position (5), red probe is over fault.
  - If meter deflection does not match original position each time, return to meter riser and locate fault again.

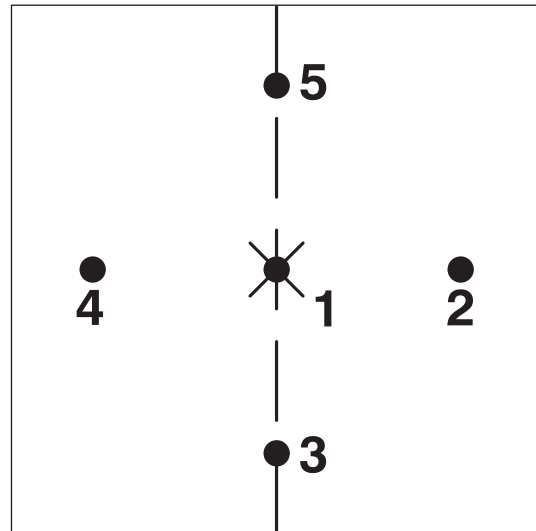

e05om016c.eps

## Troubleshooting

If transmitter has been properly connected and meter shows no deflection at the start and end of the cable, the fault is probably in the riser circuit. See "Locating Fault at Meter Riser" on page 31.



## Using Remote Probe

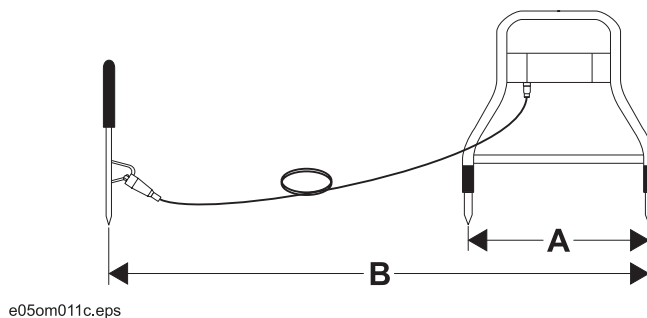

e05om011c.eps

When properly connected, remote probe can extend the detector's range from 27'/0.6 m (A) to almost 277'/8.2 m (B). Use remote probe in the following situations:

- When greater distances than allowed by the detector probes must be spanned, such as over a sidewalk, driveway or street.
- When higher sensitivity is needed to detect transmitter pulses.

## To Use

**⚠ DANGER**

Electric shock. Contacting electric lines will cause death or serious injury. Know location of lines and stay away.

**NOTICE:** Do not connect transmitter to live cable. Have qualified utility personnel disconnect cable at both ends.

1. Turn off detector.
2. Insert remote probe into remote probe cable jack under detector housing.
3. Clip other end of remote probe cable onto remote probe and push remote probe into the ground near the detector's red probe.
4. Turn on detector.
5. Press remote probe switch. A green light indicates detector is in remote mode. While remote probe is active, the built-in red probe is disabled.

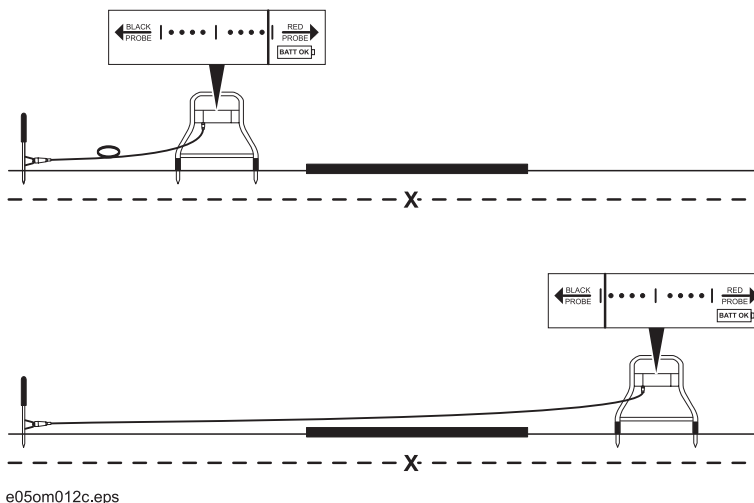

6. After remote probe is in place, move detector down line as needed and push probes into the ground.
  - To continue using remote probe, bring it even with detector's red probe and repeat step 6.
  - When remote probe is no longer needed, push remote probe switch and remove remote probe cable from detector housing. This will return detector to local mode and enable the detector's built-in red probe.

## Special Situations



**⚠ DANGER**

Electric shock. Contacting electric lines will cause death or serious injury. Know location of lines and stay away.

**NOTICE:** Do not connect transmitter to live cable. Have qualified utility personnel disconnect cable at both ends.

### Locating Fault at Meter Riser

If fault is suspected to be at or very near meter riser, try one of the methods outlined below.

1. Turn detector (1) at a 45° angle to the house and check for null reading along an imaginary line. Take at least two readings. A null reading across a line pointed at the meter riser (3) indicates a fault at the base of or in the meter riser.
2. Connect transmitter to far end of the cable and locate as usual toward the house. This method may not be practical for long cable runs.

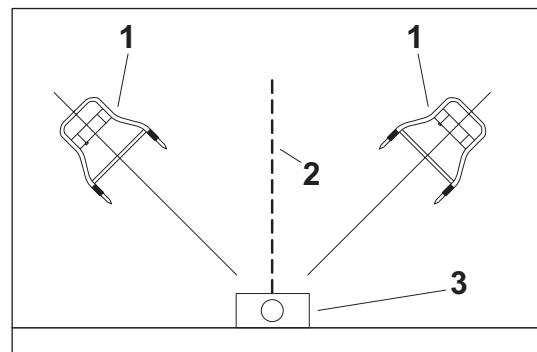

e05om013c.eps



### Locating Fault at Street Light Circuit

Have qualified utility personnel disconnect the ballast of the street light before locating fault. The ballast distorts the transmitter pulse. Once the ballast is disconnected, locate fault as usual.

## Locating Fault in Shielded Conductor

**NOTICE:** Always turn off transmitter when connecting or moving ground probe.

This system is most effective in locating faults on direct-buried, grounded faults because the transmitter pulse is allowed to travel to ground at the point of the fault. This is not always true with direct-buried, shielded conductors. To locate a fault in a shielded conductor, use one of the methods outlined below.

### Extend Transmitter Ground

1. Strip both ends of a 100-300' (30-90 m) piece of #6, #8 or #10 insulated wire.
2. Attach black clip from transmitter (2) high voltage output cable to one end of the wire. Insulate the connection.
3. Attach other end of wire to ground probe.
4. Extend the high voltage output cable (now attached to the insulated wire, 3) perpendicular to the route of the buried cable (1) as far as practical (A) within the 100-300' (30-90 m) range.
5. Push ground probe into the ground.
6. Turn on transmitter and check for pulses with detector.
7. If this is unsuccessful, move ground probe to other side of faulted cable.

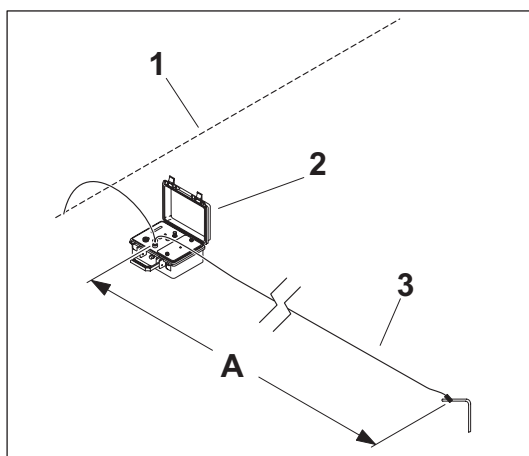

e05om014c.eps

### Use Running Ground

1. Strip both ends of a roll of #6, #8 or #10 insulated wire (4).
2. Attach black clip from transmitter (2) high voltage output cable to one end of the wire. Insulate the connection.
3. Attach other end of wire to ground probe.
4. Extend wire 30-50'/10-15 m (B) perpendicular to buried cable (1) and insert ground probe.
5. Extend reel of wire and insert ground probe parallel to the buried cable.

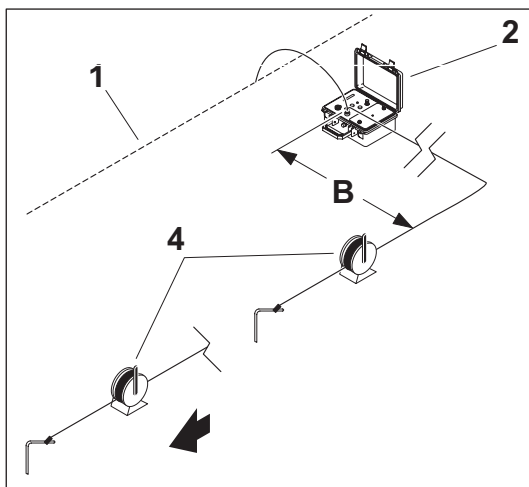

e05om015c.eps

**NOTICE:** Always turn off transmitter before moving ground probe.

### **Locating Fault Under Snow or Frozen Ground**

Frozen ground is a barrier to the transmitter pulse. To receive signal through frozen ground, drive spikes through frozen ground and touch detector probes to them. For greater sensitivity and easier handling, attach remote probe and press remote probe button.

### **Locating Fault Over Asphalt or Cement (Wet Sponge Method)**

**NOTICE:** Do not touch bare metal parts of equipment. Wear electrically-insulating rubber gloves.

In areas such as parking lots, driveways, or other paved areas where probes cannot be inserted into the ground, use wet sponge method.

1. Mix 1 cup (236 mL) of salt with 1 gal (3.8 L) of water.
2. Soak two large sponges in the solution.
3. Place sponges about 10' (3 m) apart on paved surface.
4. Attach remote probe to detector and press remote probe button.
5. Touch black probe to one sponge and remote probe to the other sponge.
6. Locate fault as usual, resoaking sponges often.





---

# Locating Concepts

## Chapter Contents

How Earth Return Faults Are Created . . . . . 36

Finding General Location of a Faulted Cable . . . 36

Locating Earth Return Faults . . . . . 37



## How Earth Return Faults Are Created

When a cable's insulation is damaged, the conductor is exposed to contact with the earth. These damaged areas interact with the earth which causes corrosion and eventually a fault that can degrade the service provided by the cable. This type of fault is called an earth return fault.

Faults can be caused by a number of actions.

- Splicing: Splices often corrode and may fault to ground.
- Excavation: Cables can be nicked but not broken by excavation equipment such as shovel, backhoe, trencher, drill head, auger, fence post, etc. These nicked areas can corrode and may fault to ground.
- Abrasion: Rocks and other abrasive elements can damage cable when the earth shifts due to soil conditions, climate and above-ground traffic.

**IMPORTANT:** Although there are other types of faults, only earth return faults can be detected with type of equipment.

## Finding General Location of a Faulted Cable

Some things to look for when searching for the general location of a faulted cable are:

- recently disturbed soil
- past splices
- "buried utility" notices
- utility facilities without overhead lines
- junction boxes
- drop boxes
- light poles
- sunken ground

## Locating Earth Return Faults

Locate earth return faults by following this procedure:

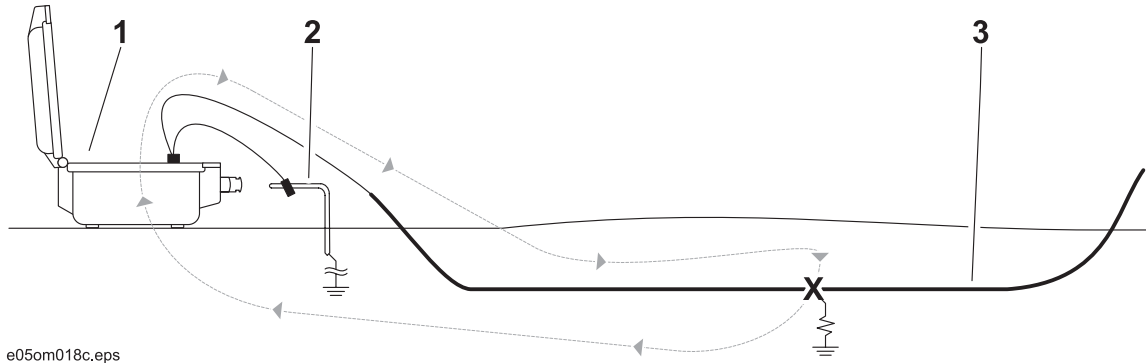

1. De-energize and disconnect the cable at both ends.
2. Connect one lead of the transmitter to the ground rod (2) and connect the other lead to one end of the cable (3).
3. Turn on transmitter (1) and use A-frame detector to probe along the cable route until fault is detected.

Isolating the cable on both ends and then energizing it with a special signal generated by a transmitter creates an electrical circuit where current flows down the cable and seeks a path back to the transmitter. The path back to the transmitter is along the path of the fault to ground. Current will not flow without a path to ground.



Calibrate the impedance meter on the transmitter before each job. After the transmitter is connected to the cable, the impedance reading will help verify that a fault exists on the cable.

- A reading of greater than 1M usually indicates no significant fault exists in the cable.
- A reading less than 1M or between 500K and 50K generally indicates that a high-resistance fault exists. This fault may not yet cause problems but it will worsen over time.
- A reading less than 50K generally indicates a heavy fault exists.

Use an A-frame detector to probe the earth and measure the current along the path of the cable. Current will be highest at the point of the fault where the current enters the ground and at the transmitter ground rod. The A-frame detector meter pulses toward the direction of the fault.

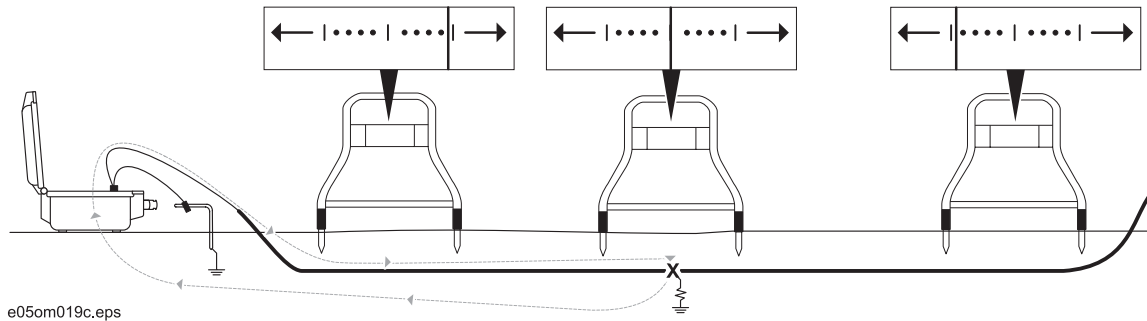

The farther the fault is from the transmitter, the more likely the analog meter will show very small or no deflection. The deflection will increase as the operator nears the fault. The signal is high at the ground rod and at the fault but drops off in between.

---

# Complete the Job

## Chapter Contents

Stow Equipment ..... 40



## **Stow Equipment**

Stow cables in carrying bag and load all equipment into truck.

---

# Service



## Chapter Contents

<b>As Needed</b> .....	<b>42</b>
• Replace detector battery .....	.42
• Replace transmitter batteries and fuse .....	.42

## As Needed

### Replace Detector Battery

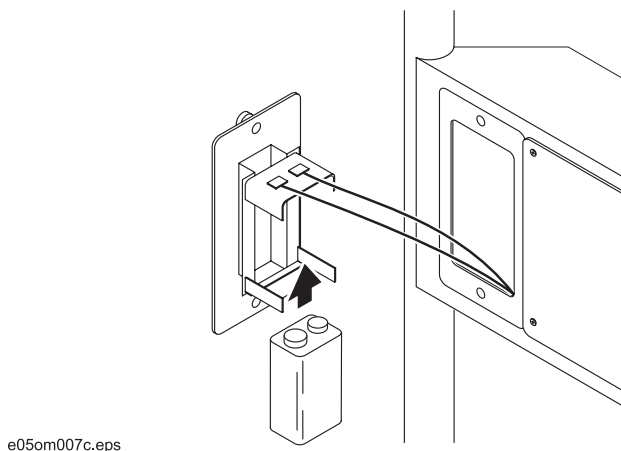

Replace 9V battery as needed. Loosen thumbscrews and remove panel to access battery. Install battery as shown.

### Replace Transmitter Batteries and Fuse

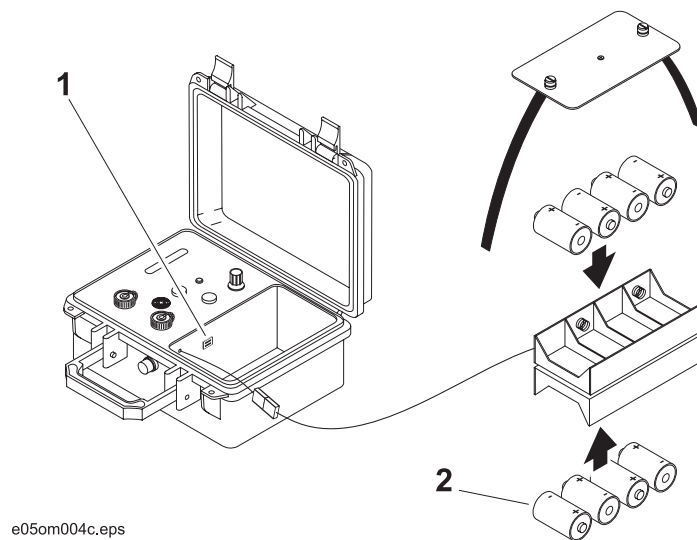

Replace 4A fuse (1) and eight D-cell batteries (2) as needed. Loosen thumbscrews and remove panel to access fuse and batteries. Loosen strap and remove used batteries. Install new batteries as shown and secure with strap.

# Specifications

## AF2

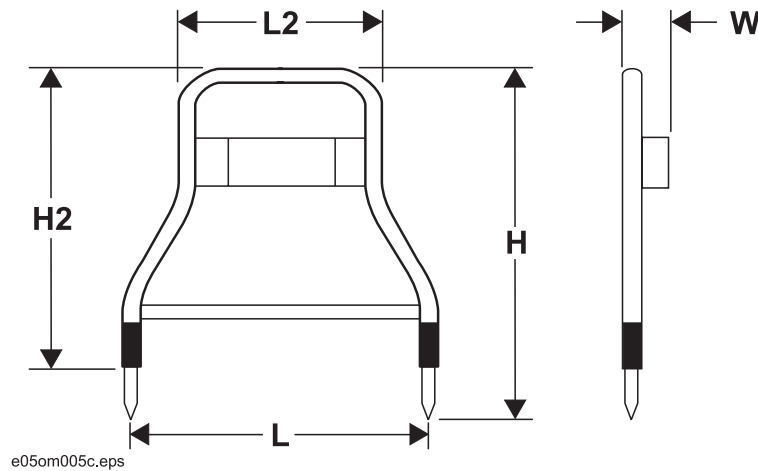

Dimensions	U.S.	Metric
L, length between probes	22 in	559 mm
L2, handle length	14.5 in	368 mm
H, height from probe tip to carrying handle	32.8 in	833 mm
H2, height from probe base to carrying handle	28.3 in	719 mm
W, width	2.4 in	61 mm
Weight	4.5 lb	2.0 kg

### Operation

Adjustable sensitivity and gauge centering

Battery level and analog meter direction indicators

Electronically switchable local/remote probe

### Battery

Type: 9V DC alkaline. Life: 65 hours

Rechargeable nickel-cadmium can be used but operation time will be reduced.

# FT14

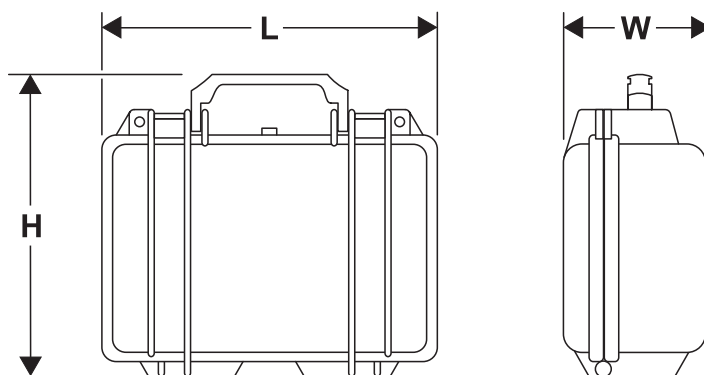

e050m006c.eps

Dimensions	U.S.	Metric
L, length	10.5 in	267 mm
H, height	11 in	279 mm
W, width	4.9 in	125 mm
Weight, with batteries	7.2 lb	3.2 kg

Operation
Output voltage: 2300-2500V DC typical across 10 megaohm load; 50V DC typical across 625 ohm load.
Output pulse rate: 1 every 3-4 seconds. Output pulse duration: 200 milliseconds, typical
Fault impedance indicator (500 ohm to 1 megaohm)
User-selected on/off for audio and light output indicators

Power Requirements
D-cell batteries or 12V DC external power source required.
Batteries: 8 D-cell alkaline batteries. Life: 160 hours. Rechargeable nickel-cadmium can be used but operation time will be reduced.
12V DC external source through supplied cable: 12V DC @ 24W - pulsing; 12V DC @ 0.5W - normal.
12V DC input protected with 4A, panel-mount fuse.

Specifications are general and subject to change without notice. If exact measurements are required, equipment should be weighed and measured.

# Support

## Procedure

Notify your dealer immediately of any malfunction or failure of Subsite Electronics equipment.

Always give model, serial number, and approximate date of your equipment purchase. This information should be recorded and placed on file by the owner at the time of purchase.

Return damaged unit to dealer for inspection and warranty consideration if in warranty time frame.

All repairs must be done by an authorized Subsite Electronics repair facility. Repairs done elsewhere will void warranty consideration.

## Resources

### Publications

Contact your Subsite Electronics dealer for publications and videos covering safety, operation, service, and repair of your equipment.

### Training

For information about on-site, individualized training, contact your Subsite Electronics dealer.



# Warranty

## Subsite Electronics Limited Product Warranty Policy

### Warranty Periods

#### New Product

A twelve-month period starts on the date of delivery to the end user:

Receivers: 300SR, 950R, EML  
Transmitters: 300ST, 950T, 970T  
Fault Finders: AF1, FT12, AF2, FT14

A six-month period starts on the date of delivery to the end user:

Beacons: 11B, 910B

A three-month period starts on the date of delivery to the end user:

Beacons: BI  
Accessories: cables, clamps, and adapters

#### Used Product (Cosmetics)

A three-month warranty starts on the date of delivery to the end user. (Non-returnable) All used products have an RS added after the serial number.

#### Service and Repair

A one-month warranty on **labor** starts on the date the unit is repaired, and a three-month warranty on **parts** starts on the date the unit is repaired for all products.

#### Extended Warranty

The extended warranty may be purchased at the time the equipment is sold or within thirty days of ownership. The extension is for an additional twenty-four months, for a total coverage of thirty-six months.

### Details and Exclusions

- The warranty includes only Subsite Electronics products and accessories that are manufactured and distributed by Subsite Electronics. The warranty compensates on defects in material or workmanship.
- Defects will be determined through inspection by Subsite Electronics or authorized repair centers. Original purchaser must make the defective item available for inspection within 30 days of the date the part fails.
- The warranty is limited to replacement of the defective part. The replacement part may be new or remanufactured. Repair and installation of defective part will be at no charge when product or item is delivered to Subsite Electronics or an authorized repair center. The product or item will be returned at no charge for return freight.
- The warranty periods do not represent the useful life of Subsite Electronics products and accessories.
- If Subsite Electronics products are purchased for commercial purposes, as defined by the commercial code, no warranties extend beyond the specific terms set forth in this limited warranty. All other provisions of this limited warranty apply, including the duties imposed.
- Subsite Electronics products have been tested to deliver acceptable performance in most conditions.
- This limited warranty applies to the original purchaser only. Some states or jurisdictions do not allow exclusion or limitation of incidental or consequential damages, so above limitation may not apply. This limited warranty gives original purchaser specific rights that vary from state to state or jurisdiction to jurisdiction.
- The Subsite Electronics Equipment Registration Form must be completed for each serial numbered product and submitted to Subsite Electronics. The information on the form is used to establish the warranty period start date.
- When the Subsite Electronics Equipment Registration Form is not processed and received by Subsite Electronics, the Subsite Electronics shipping date is used to establish the warranty period start date.
- Product inspection and estimates may require that the unit be disassembled and tested.
- Out-of-warranty inspection costs include labor accrued at the full labor rate plus return freight.
- Approved out-of-warranty repair costs include parts, labor accrued at full labor rate, plus return freight.



